

SEELA

Antti Kotilainen | 2018



SEELA

Antti Kotilainen | 2018

When they communicate, it is the best of all possible worlds. Man and nature together, one observes, the other suggests shapes and materials. This extraordinary encounter has led to a lesson in Finnish design. The encounter between Antti Kotilainen and Lapalma has resulted in SEELA, a chair that expresses beauty, with spontaneous contact between wood, polypropylene and steel. The sinuous shell on light bases has an integrated seamless seat-pad. Countless variations. Much serenity.



SEELA

Antti Kotilainen | 2018



| S310 Stackable with slide-frame base

Shell in polypropylene with integrated seamless seatpad in polypropylene, wood or fabric, easily removable with 4 screws and replaceable. A fully upholstered shell without removable seat-pad is also available. Stackable sled base in steel rod either mat chromed or powder coated. Glides in polypropylene with insert in felt or plastic. It is complemented by a stool in two heights.

TEST EN 1728:2012 AC:2013 6.17 - EN 16139:2013 - L2 extreme

TEST Fire resistance - class 1 - PP

TEST 1 IM - Jet, Remix, Tonica, Valencia

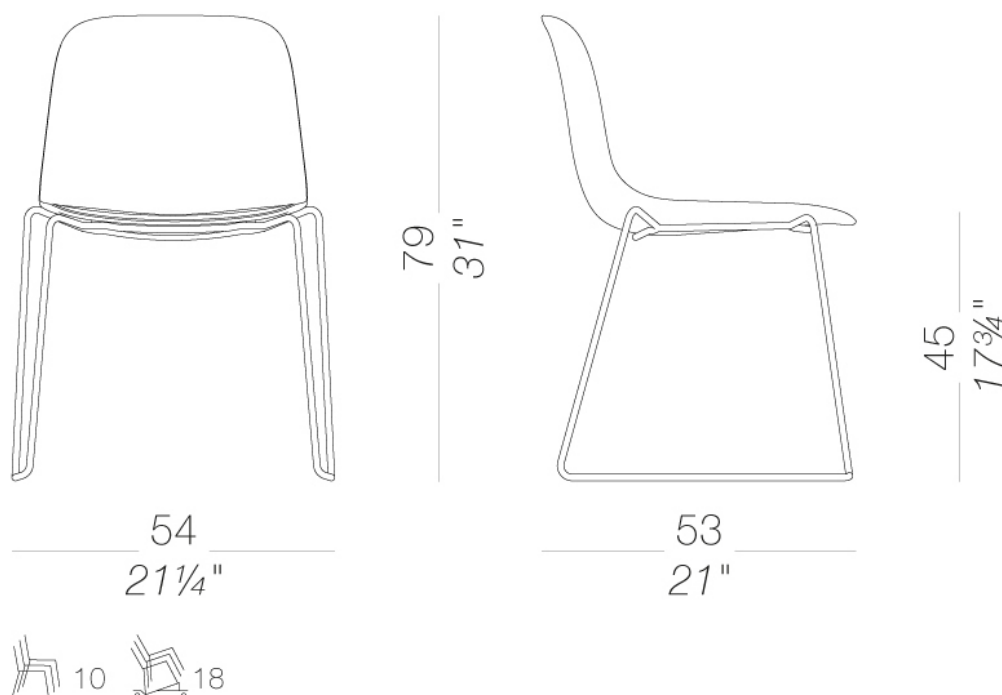

SEELA

Antti Kotilainen | 2018

| S314 stackable with armrests

Shell in polypropylene with integrated seamless seatpad in polypropylene, wood or fabric, easily removable with 4 screws and replaceable. A fully upholstered shell without removable seat-pad is also available. Stackable sled base in steel rod either mat chromed or powder coated. Armrests in polypropylene. Glides in polypropylene with insert in felt or plastic.

TEST Fire resistance - class 1 - PP
TEST 1 IM - Jet, Remix, Tonica, Valencia

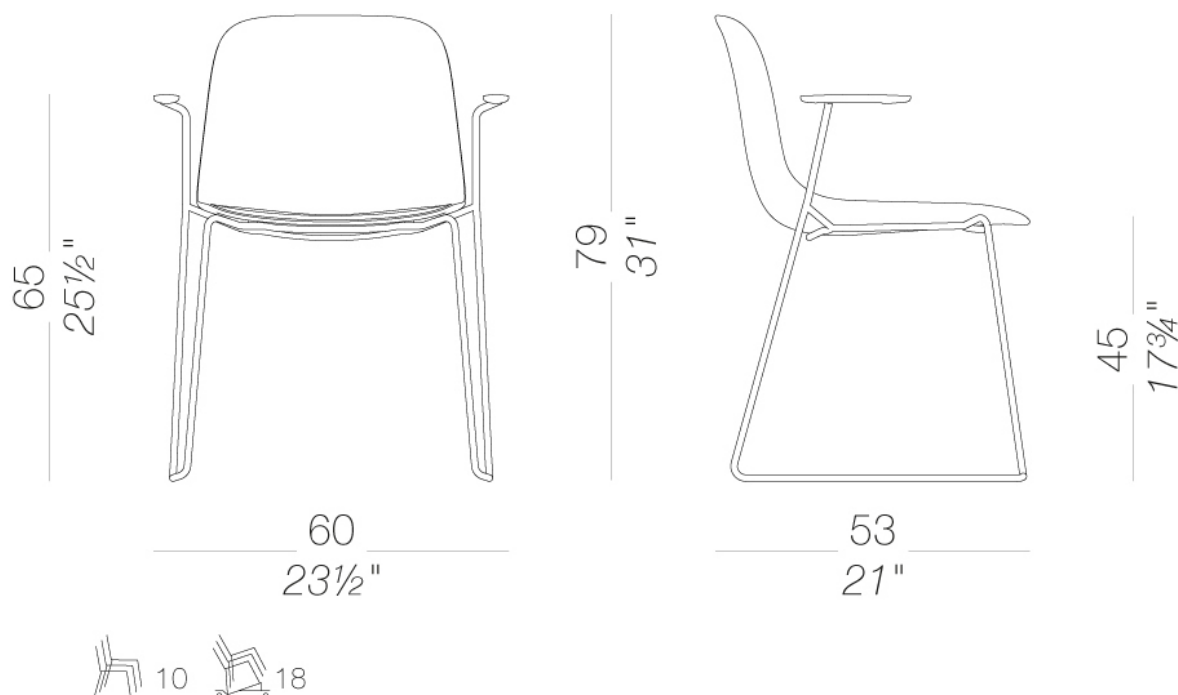

SEELA

Antti Kotilainen | 2018

| S315 with writing arm

Shell in polypropylene with integrated seamless seatpad in polypropylene, wood or fabric, easily removable with 4 screws and replaceable. A fully upholstered shell without removable seat-pad is also available. Sled base in steel rod either mat chromed or powder coated. Pivoting writing tablet in black or white Fenix®. Glides in polypropylene with insert in felt or plastic.

TEST Fire resistance - class 1 - PP
TEST 1 IM - Jet, Remix, Tonica, Valencia

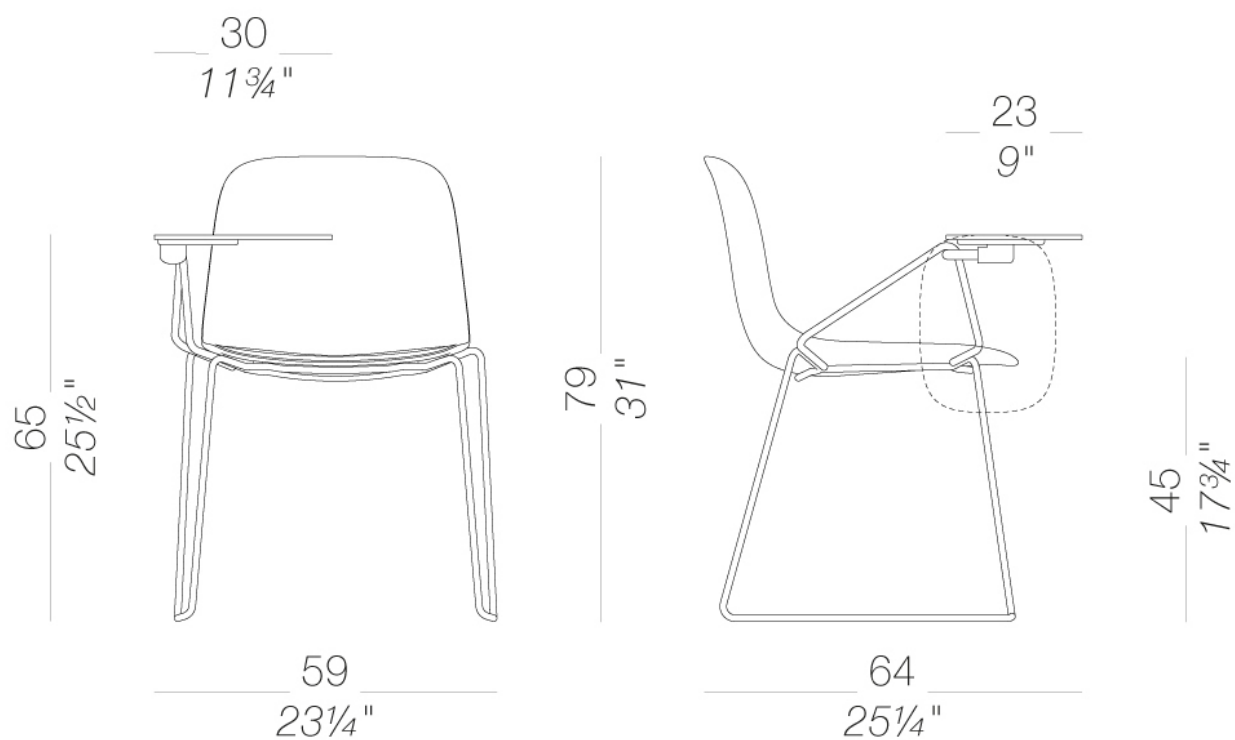

SEELA

Antti Kotilainen | 2018

| S311 4-legged

Shell in polypropylene with integrated seamless seatpad in polypropylene, wood or fabric, easily removable with 4 screws and replaceable. A fully upholstered shell without removable seat-pad is also available. 4 legged stackable base in mat chromed steel or powder coated. Glides in nylon with felt.

TEST EN 1728:2012 AC:2013 6.17 - EN 16139:2013 - L2 extreme

TEST Fire resistance - class 1 - PP

TEST 1 IM - Jet, Remix, Tonica, Valencia

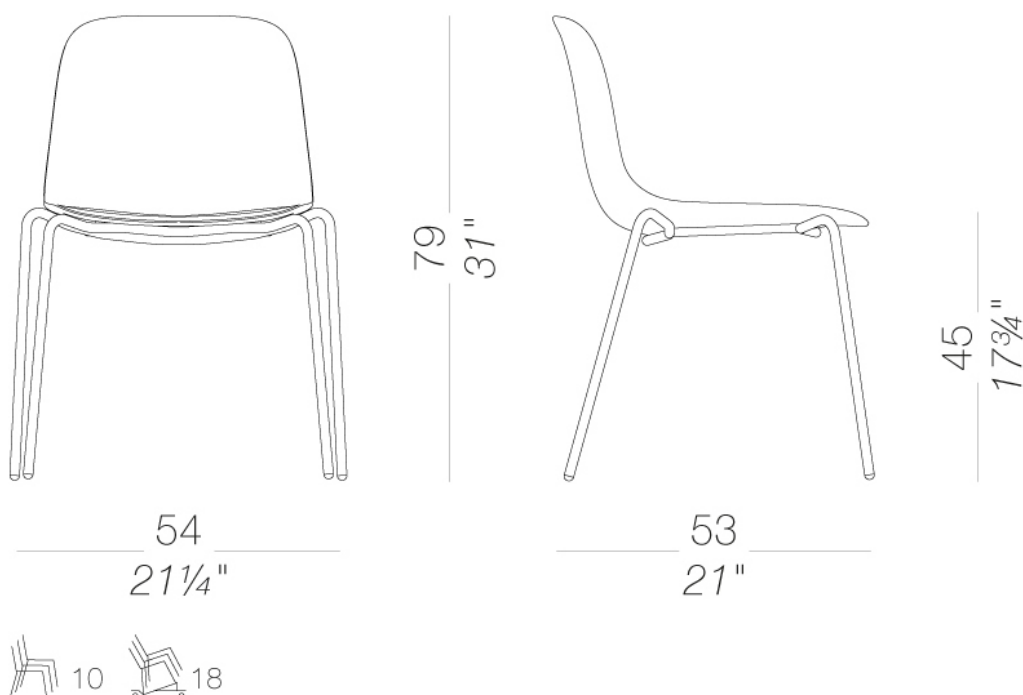

SEELA

Antti Kotilainen | 2018

| S316 stackable with armrests

Shell in polypropylene with integrated seamless seatpad in polypropylene, wood or fabric, easily removable with 4 screws and replaceable. A fully upholstered shell without removable seat-pad is also available. Stackable base 4 legs in mat chromed steel or powder coated. Armrests in polypropylene. Glides in nylon with felt.

TEST Fire resistance - class 1 - PP
TEST 1 IM - Jet, Remix, Tonica, Valencia

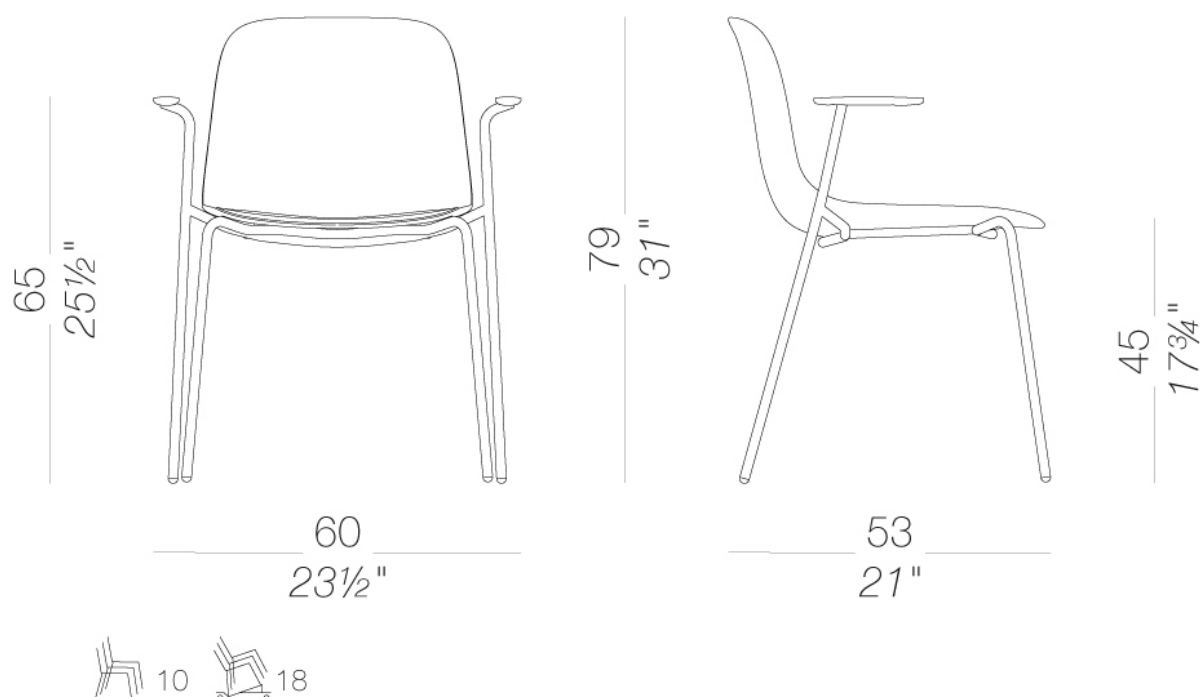

SEELA

Antti Kotilainen | 2018

| S317 with writing arm

Shell in polypropylene with integrated seamless seatpad in polypropylene, wood or fabric, easily removable with 4 screws and replaceable. A fully upholstered shell without removable seat-pad is also available. Base with 4 legs in mat chromed steel or powder coated. Pivoting writing tablet in black or white Fenix®. Glides in nylon with felt.

TEST Fire resistance - class 1 - PP
TEST 1 IM - Jet, Remix, Tonica, Valencia

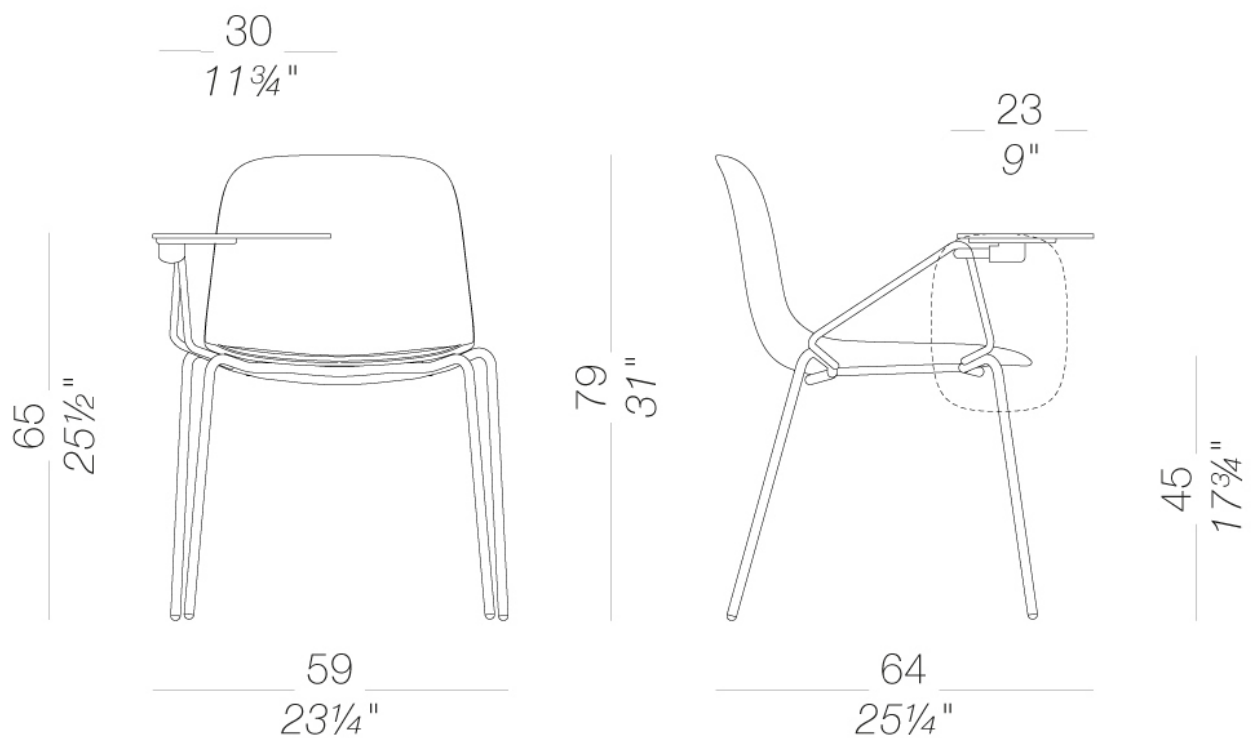

SEELA

Antti Kotilainen | 2018

| S312 4-legged

Shell in polypropylene with integrated seamless seatpad in polypropylene, wood or fabric, easily removable with 4 screws and replaceable. A fully upholstered shell without removable seat-pad is also available. Base with 4 legs in mat chromed steel or powder coated. Glides in nylon with felt. It is complemented by a stool in two heights.

TEST Fire resistance - class 1 - PP
TEST 1 IM - Jet, Remix, Tonica, Valencia

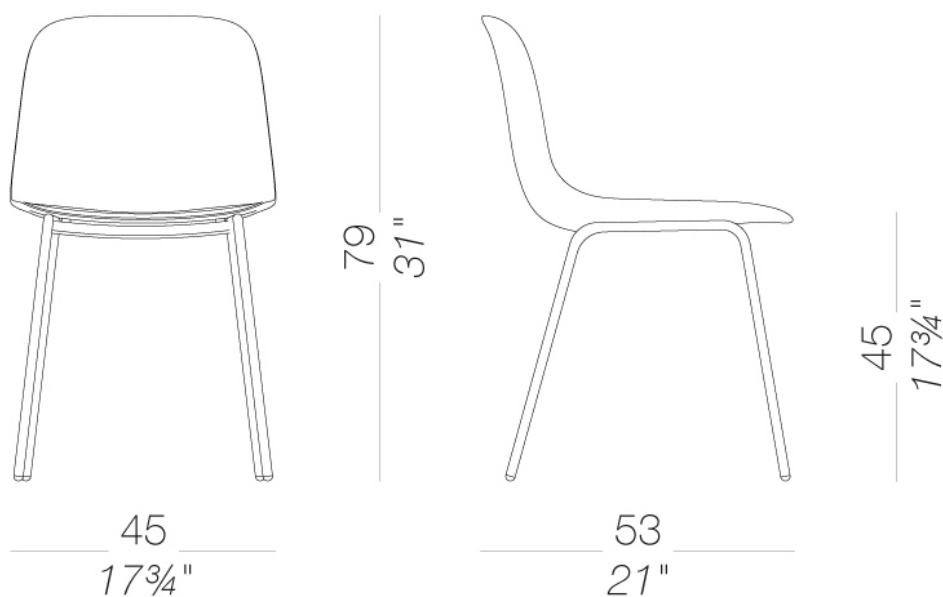

SEELA

Antti Kotilainen | 2018

| S313 Chair with wood legs

Shell in polypropylene with integrated seamless seatpad in polypropylene, wood or fabric, easily removable with 4 screws and replaceable. A fully upholstered shell without removable seat-pad is also available. Base with 4 legs in solid wood lacquered in several finishes. Glides in nylon with felt. It is complemented by a stool in two heights.

TEST Fire resistance - class 1 - PP
TEST 1 IM - Jet, Remix, Tonica, Valencia

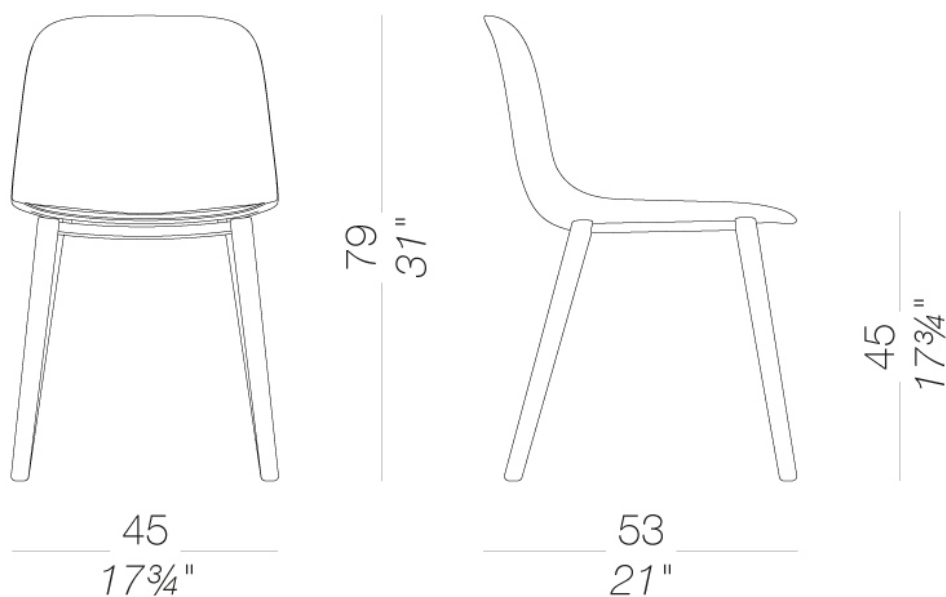

SEELA

Antti Kotilainen | 2018

| S344 Trestle swivel base

Shell in polypropylene with integrated seamless seatpad in polypropylene, wood or fabric, easily removable with 4 screws and replaceable. A fully upholstered shell without removable seat-pad is also available. Trestle swivel base in sandblasted aluminium or powder coated. Glides in polythene.

TEST Fire resistance - class 1 - PP
TEST 1 IM - Jet, Remix, Tonica, Valencia

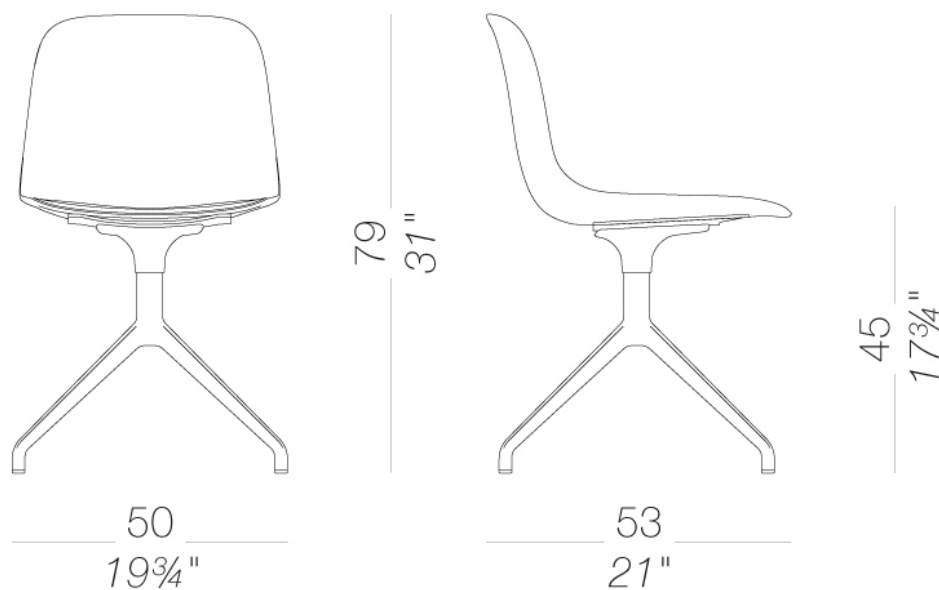

SEELA

Antti Kotilainen | 2018

| S345 Trestle swivel base with armrest

Shell in polypropylene with integrated seamless seatpad in polypropylene, wood or fabric, easily removable with 4 screws and replaceable. A fully upholstered shell without removable seat-pad is also available. Trestle swivel base in sandblasted aluminium or powder coated. Armrests in polypropylene. Glides in polythene.

TEST Fire resistance - class 1 - PP
TEST 1 IM - Jet, Remix, Tonica, Valencia

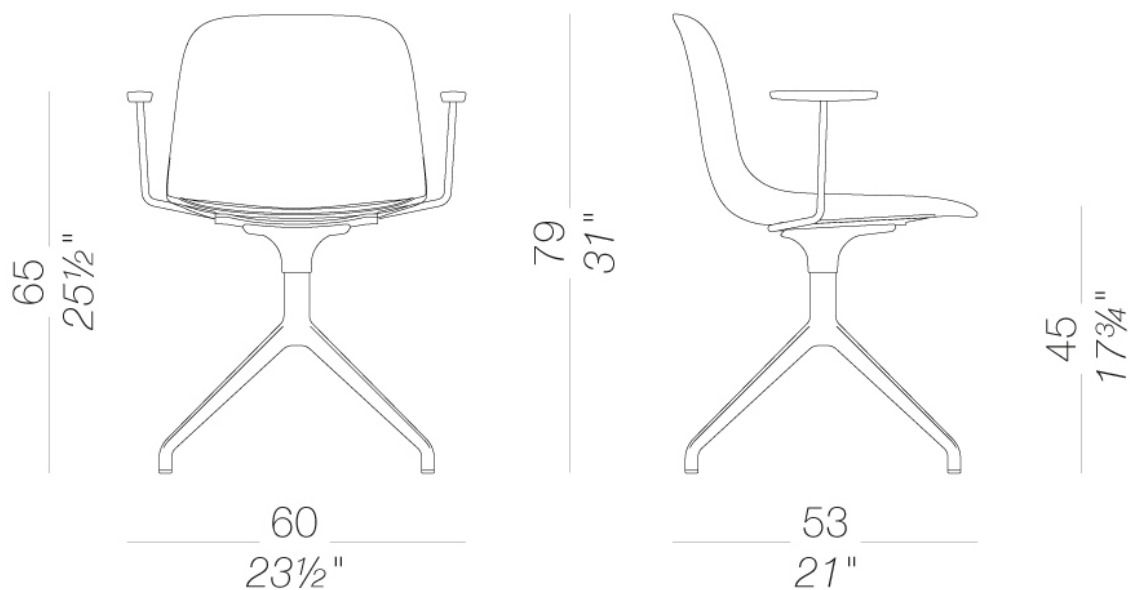

SEELA

Antti Kotilainen | 2018

| S340 Height-adjustable with pyramidal base, on castors

Shell in polypropylene with integrated seamless seatpad in polypropylene, wood or fabric, easily removable with 4 screws and replaceable. A fully upholstered shell without removable seat-pad is also available. Five-star swivel height adjustable base in sandblasted aluminium or powder coated, with self-braking castors.

TEST Fire resistance - class 1 - PP
TEST 1 IM - Jet, Remix, Tonica, Valencia

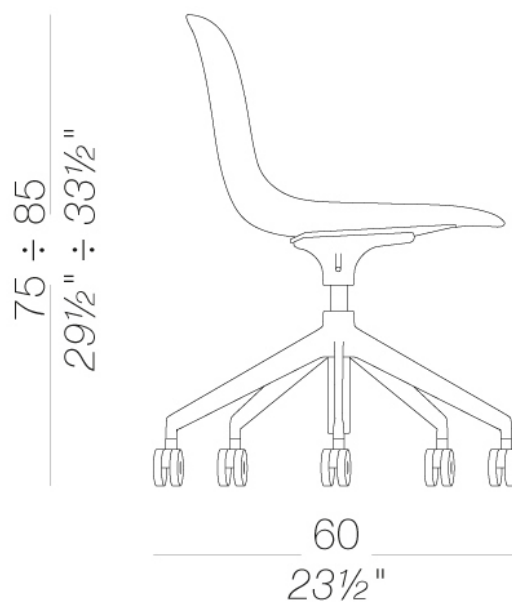
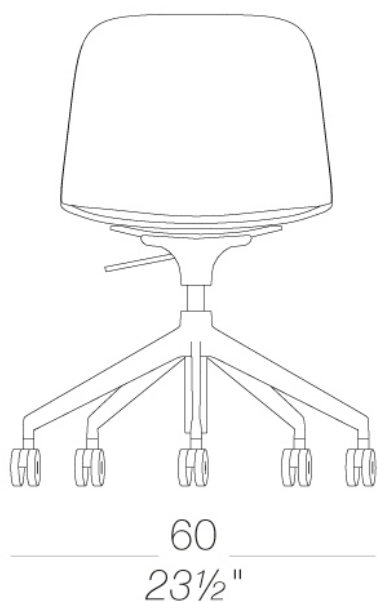

SEELA

Antti Kotilainen | 2018

| S341 swivel with armrests

Shell in polypropylene with integrated seamless seatpad in polypropylene, wood or fabric, easily removable with 4 screws and replaceable. A fully upholstered shell without removable seat-pad is also available. Five- star swivel height adjustable base in sandblasted aluminium or powder coated, with self-braking castors. Armrests in polypropylene.

TEST Fire resistance - class 1 - PP
TEST 1 IM - Jet, Remix, Tonica, Valencia

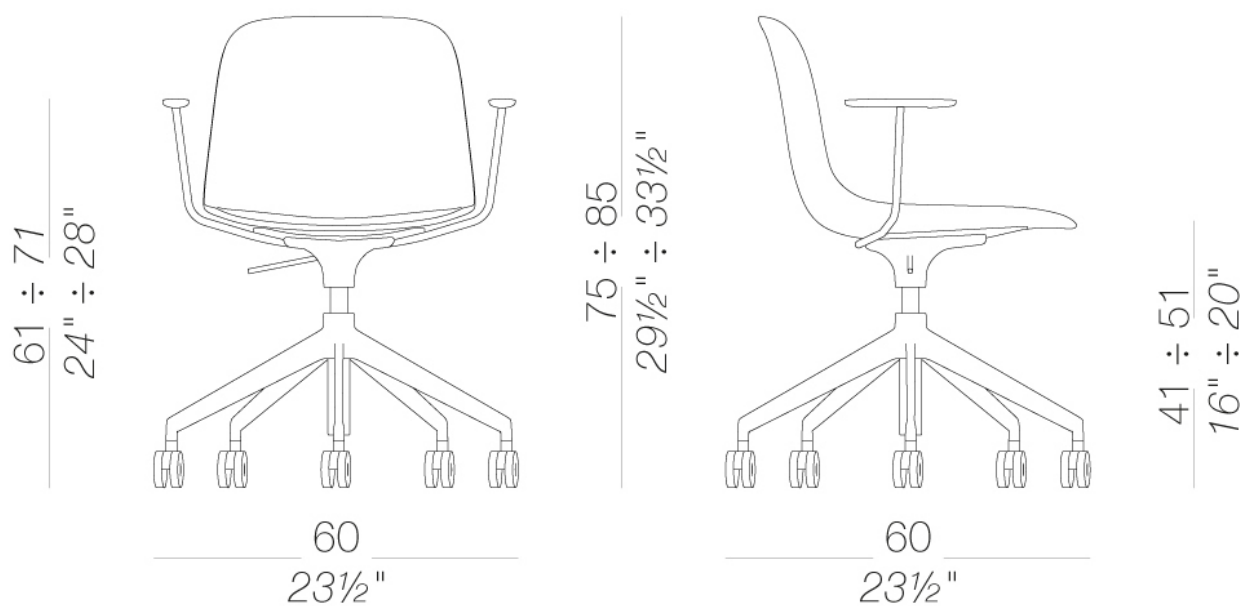

SEELA

Antti Kotilainen | 2018

| S342 4-spoke base, on castors

Shell in polypropylene with integrated seamless seatpad in polypropylene, wood or fabric, easily removable with 4 screws and replaceable. A fully upholstered shell without removable seat-pad is also available. Trestle base in sandblasted aluminium or powder coated, with self-braking castors.

TEST Fire resistance - class 1 - PP
TEST 1 IM - Jet, Remix, Tonica, Valencia

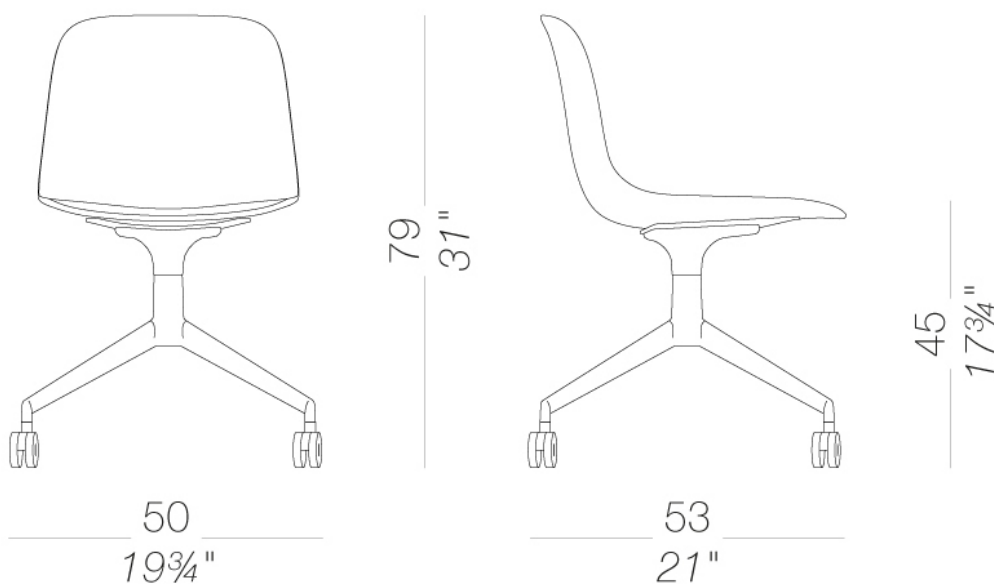

SEELA

Antti Kotilainen | 2018

| S343 Trestle base with castors and armrests

Shell in polypropylene with integrated seamless seatpad in polypropylene, wood or fabric, easily removable with 4 screws and replaceable. A fully upholstered shell without removable seat-pad is also available. Trestle base in sandblasted aluminium or powder coated, with self-braking castors. Armrests in polypropylene.

TEST Fire resistance - class 1 - PP
TEST 1 IM - Jet, Remix, Tonica, Valencia

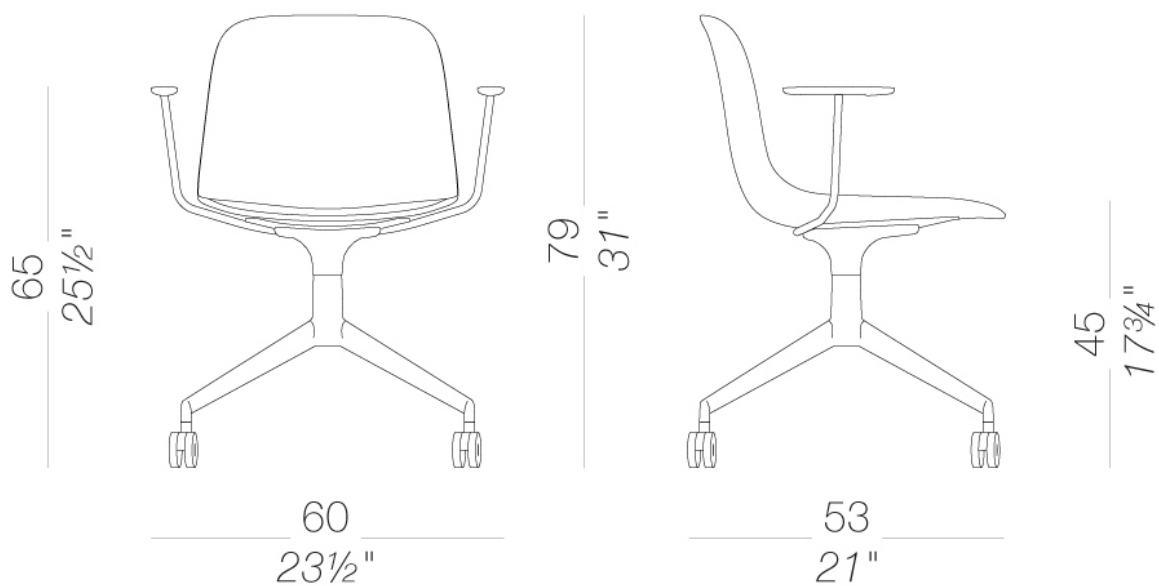

SEELA

Antti Kotilainen | 2018

| S320 counter stool with slide-frame base H65

Shell in polypropylene with integrated seamless seatpad in polypropylene, wood or fabric, easily removable with 4 screws and replaceable. A fully upholstered shell without removable seat-pad is also available. Stackable sled base h.65 cm. in steel rod either mat chromed or powder coated. Glides in polypropylene with insert in felt or plastic.

TEST Fire resistance - class 1 - PP
TEST 1 IM - Jet, Remix, Tonica, Valencia

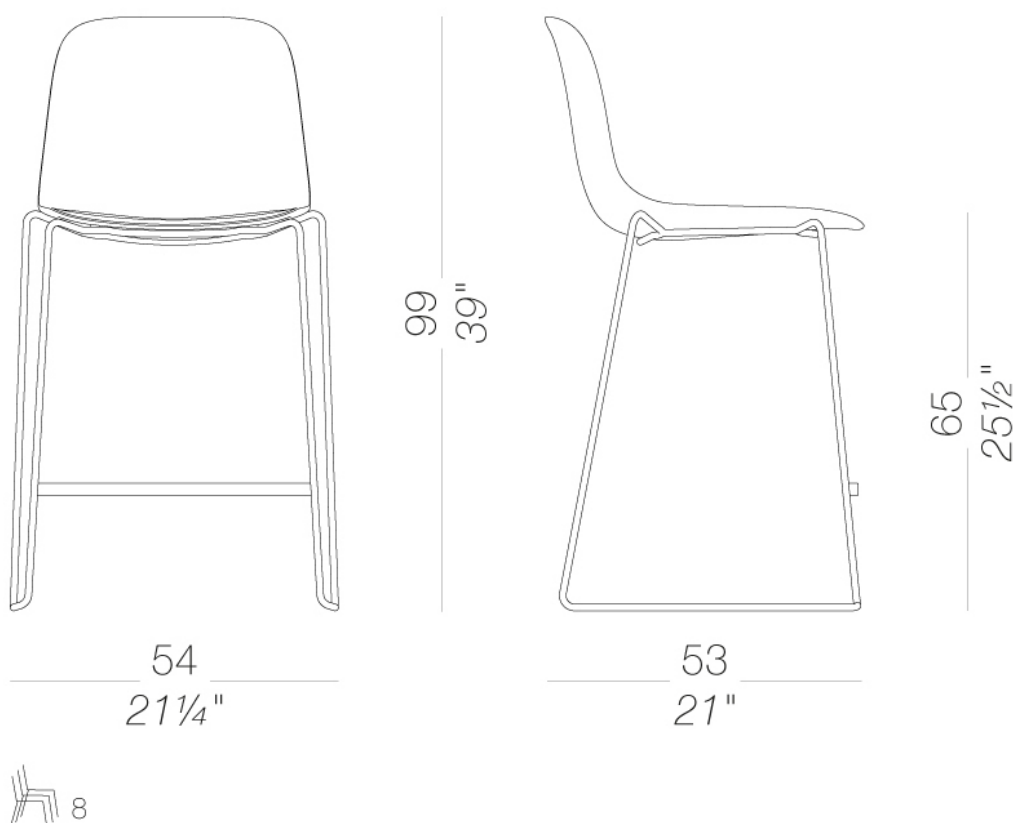

SEELA

Antti Kotilainen | 2018

| S321 bar stool with slide-frame base H75

Shell in polypropylene with integrated seamless seatpad in polypropylene, wood or fabric, easily removable with 4 screws and replaceable. A fully upholstered shell without removable seat-pad is also available. Stackable sled base h.75 cm. in steel rod either mat chromed or powder coated. Glides in polypropylene with insert in felt or plastic.

TEST Fire resistance - class 1 - PP
TEST 1 IM - Jet, Remix, Tonica, Valencia

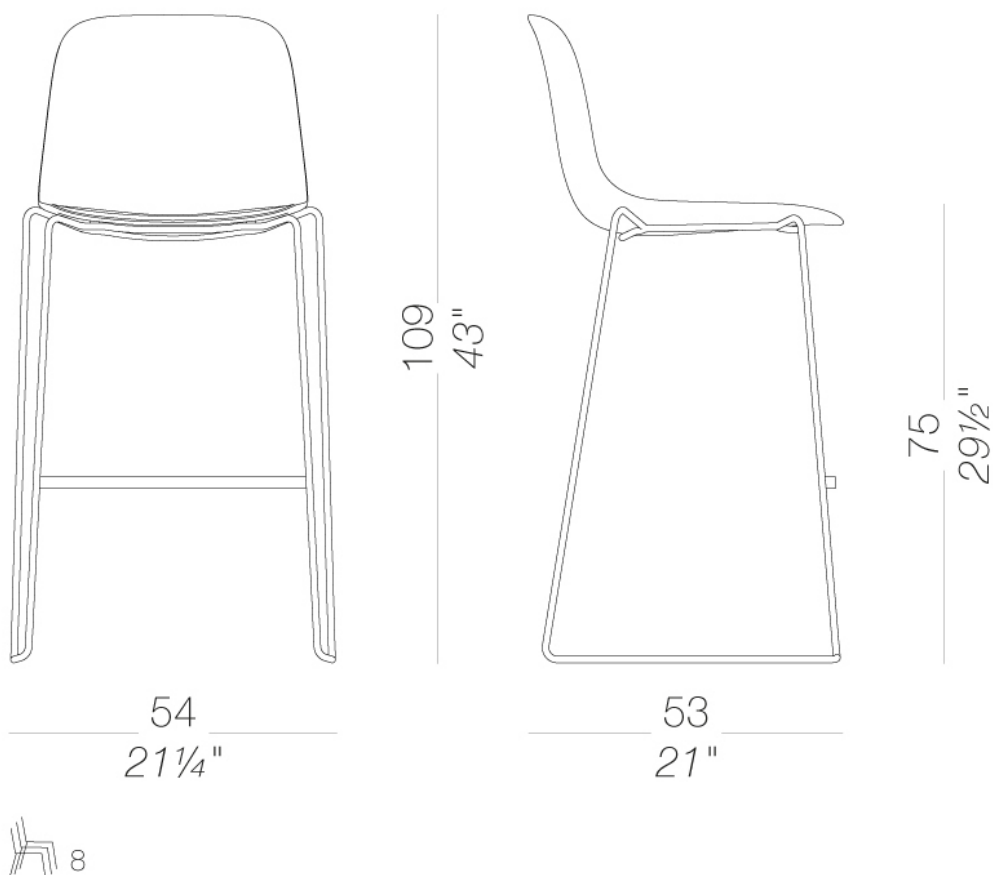

SEELA

Antti Kotilainen | 2018

| S322 4 legs counter stool H65

Shell in polypropylene with integrated seamless seatpad in polypropylene, wood or fabric, easily removable with 4 screws and replaceable. A fully upholstered shell without removable seat-pad is also available. Base h.65 cm. with 4 legs in mat chromed steel or powder coated. Feet in nylon with felt.

TEST Fire resistance - class 1 - PP
TEST 1 IM - Jet, Remix, Tonica, Valencia

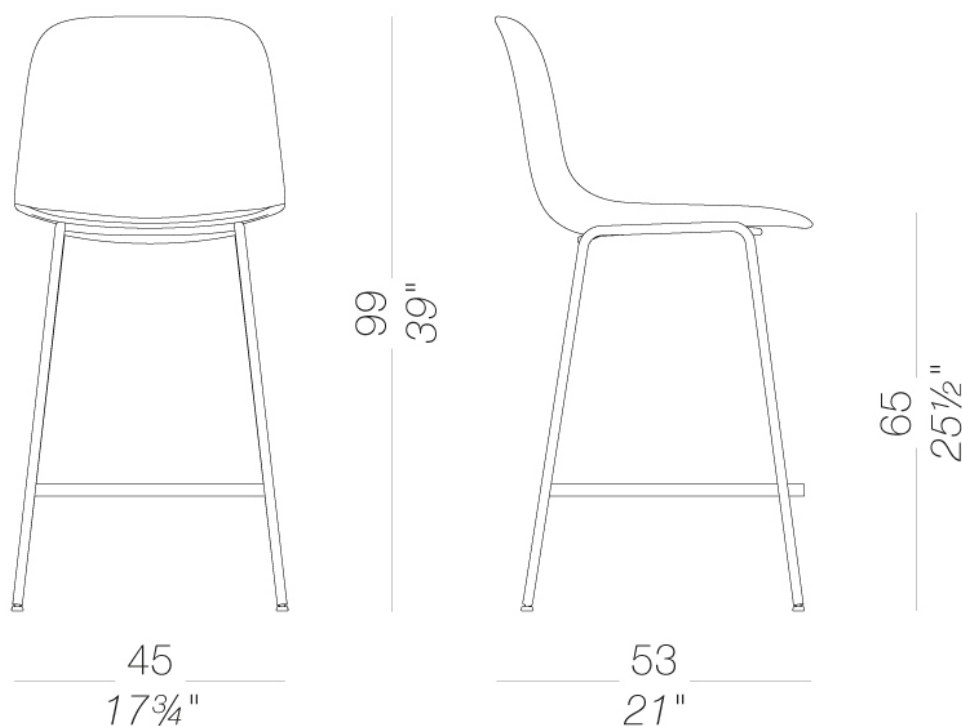

SEELA

Antti Kotilainen | 2018

| S323 4 legs H75 bar stool

Shell in polypropylene with integrated seamless seatpad in polypropylene, wood or fabric, easily removable with 4 screws and replaceable. A fully upholstered shell without removable seat-pad is also available. Base h.75 cm. with 4 legs in mat chromed steel or powder coated. Feet in nylon with felt.

TEST Fire resistance - class 1 - PP
TEST 1 IM - Jet, Remix, Tonica, Valencia

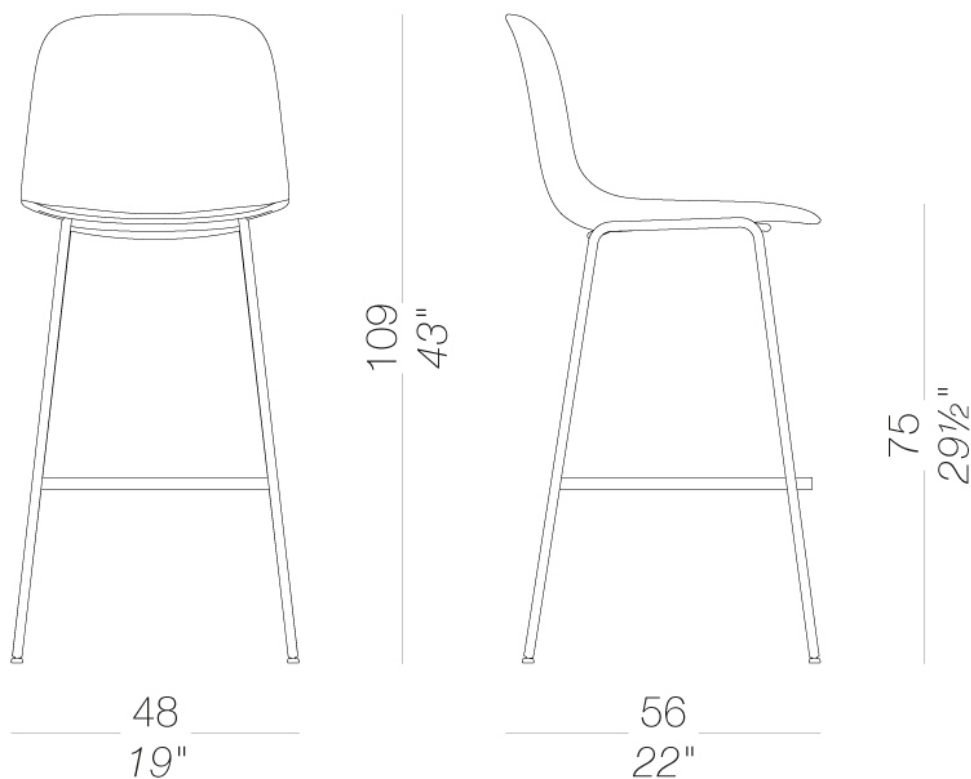

SEELA

Antti Kotilainen | 2018

| S326 4 wooden legs counter stool H65

Shell in polypropylene with integrated seamless seatpad in polypropylene, wood or fabric, easily removable with 4 screws and replaceable. A fully upholstered shell without removable seat-pad is also available. Base h.65 cm. with 4 legs in solid wood in several finishes. Footrest in steel powder coated white or black. Feet in nylon with felt.

TEST Fire resistance - class 1 - PP
TEST 1 IM - Jet, Remix, Tonica, Valencia

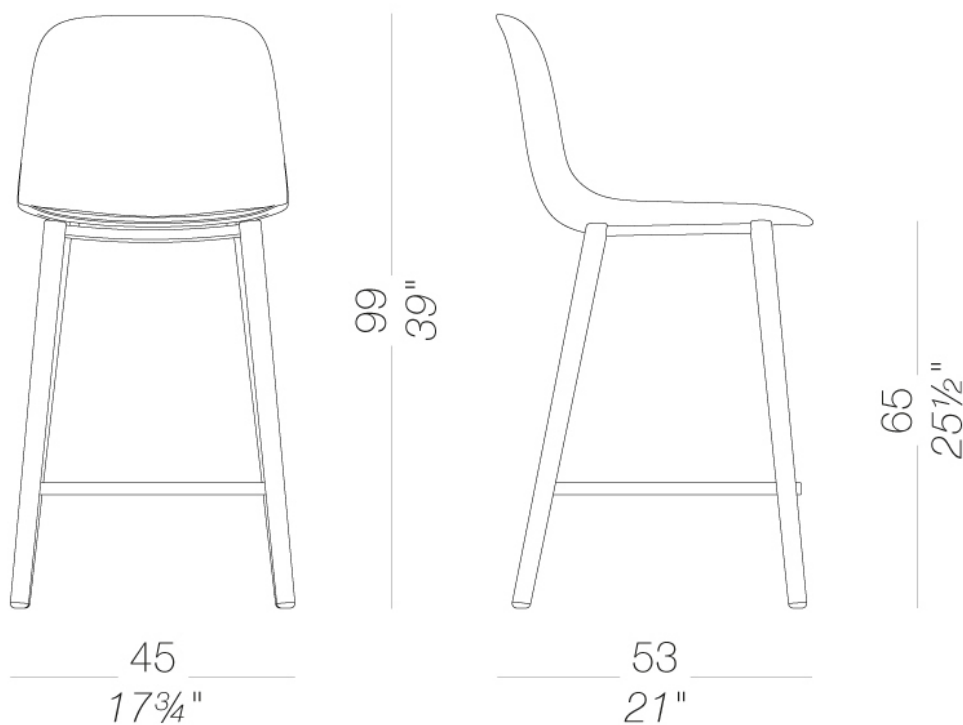

SEELA

Antti Kotilainen | 2018

| S327 bar stool with 4 wooden legs H75

Shell in polypropylene with integrated seamless seatpad in polypropylene, wood or fabric, easily removable with 4 screws and replaceable. A fully upholstered shell without removable seat-pad is also available. Base h.75 cm. with 4 legs in solid wood in several finishes. Footrest in steel powder coated white or black. Feet in nylon with felt.

TEST Fire resistance - class 1 - PP
TEST 1 IM - Jet, Remix, Tonica, Valencia

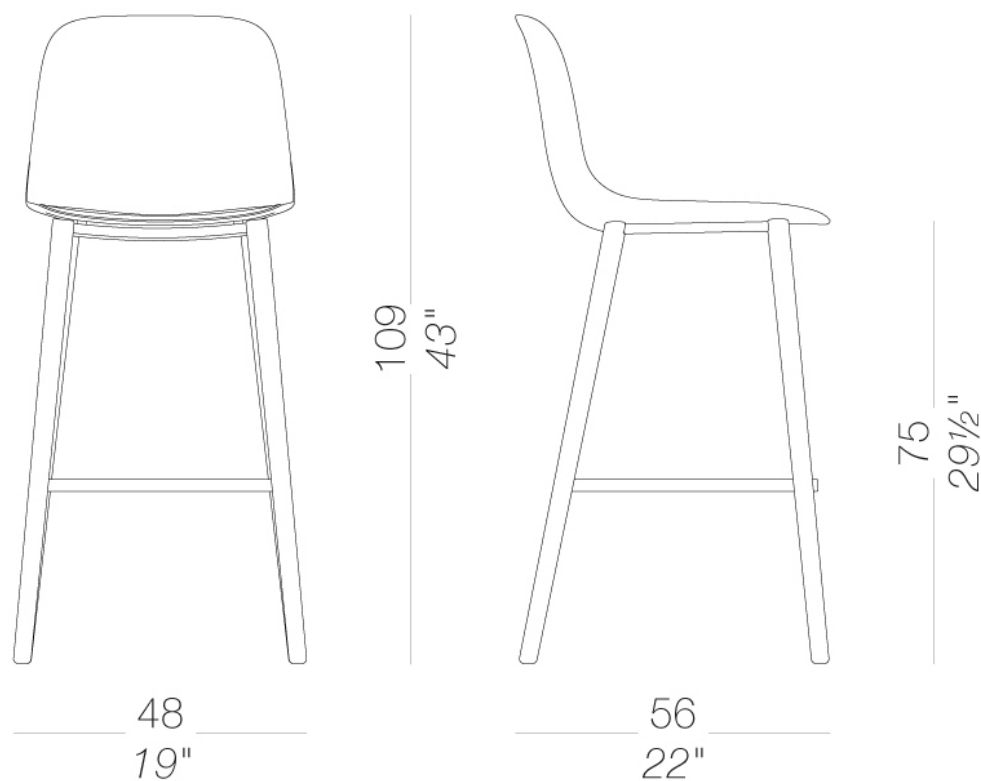

SEELA

Antti Kotilainen | 2018

frame



powder coating
perla
1 Colors

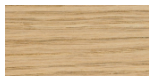

wood
blanch oak
1 Colors



powder coating
black
1 Colors

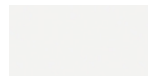

powder coating
white
1 Colors



powder coating
celeste
1 Colors

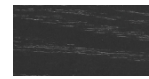

wood
black open pore
1 Colors



powder coating
mattone
1 Colors



metal
aluminium
1 Colors



powder coating
caffè
1 Colors



powder coating
oliva
1 Colors



powder coating
tortora
1 Colors



metal
mat chromed
1 Colors

shell



plastics
polypropylene
9 Colors

seat-pad



plastics
polypropylene
9 Colors

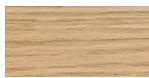

wood
blanch oak
1 Colors

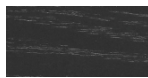

wood
black open pore
1 Colors

upholstery



fabric
Canvas 2
45 Colors



fabric
Steelcut Trio 3
54 Colors



fabric
Remix 3
72 Colors



fabric
Tonica 2
39 Colors



fabric
Medley
37 Colors

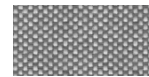

fabric
Maya
43 Colors



fabric
Jet
66 Colors



fabric
Lapalma Smart
18 Colors



fabric
Capture
43 Colors



fabric
Crisp
40 Colors

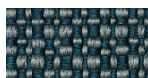

fabric
Iris
24 Colors



ecoleather
GRIMM FR
24 Colors



ecoleather
Valencia
59 Colors

armrests



plastics
polypropylene
9 Colors

tablet



HPL 10 mm

HPL fenix

2 Colors

consult the portfolio for the range of colors, fabrics, eco-leather, soft-leather.

use and maintenance instructions

Clean all parts in wood, leather, fabric and metal with a damp cloth or a diluted neutral cleaner. Do not use cleaners with alcohol, bleach, solvent or abrasive products. Any liquid spilled on the product must be wiped up immediately. When lifting or moving the product, hold it on the structure and not under the seat. The product should not be subjected to unbalanced weights, as it is designed for a proper rest on the foothold (on four legs or on the base). Our company relieves from any responsibility in case of damage caused to fragile floors. Avoid any improper use of the product: do not step on the product, on the footrest or on the armrests. Avoid any movements that could compromise the proper functionality of the product or the safety of the users. Wood and leather, being natural materials, could be easily damaged. Small impurities or imperfections are within quality standard range. Do not expose the product to weather conditions or atmospheric agents, nor to heat sources over 40°C. Also products for outdoor use could be afflicted by atmospheric agents. The product could undergo possible exterior changes due to particular exposure to heat, humidity and saltiness. An appropriate and frequent maintenance and cleaning of the product enhances its durability. The product could change colour and shade, if exposed to direct sunlight. Maintenance has to be carried out by experienced staff. Dispose of the package only after assembling the product, in order to avoid the loss of ironmongery and components. Once the product has been dismantled, the product itself or its components must be given to the public garbage disposal system, according to the legislation in force.